



INSTALLING A GAS WATER HEATER

While it appears to be a complex job, installing a water heater is really quite straightforward. Gas line connections are fairly simple, but great care has to be taken to ensure that the threaded joints are well sealed. The most difficult part for most people is soldering the copper pipe. (Note: Replacing a hot water heater requires a permit in most communities.)

When you purchase a replacement tank, you'll need to know whether your old one was "short" (about 48" in height) or "tall" (about 60" in height). There is no difference in capacity (all 40-gallon tanks hold the same amount of water), but the gas and water supply lines, as well as the flue pipe, will be at different heights, depending on which type or brand of tank you have. It's far easier to stay with the height you already have, so you won't have to change the piping.

In earlier models, the main differences in quality among various heaters were in the amount of insulation around the inner tank and in the recovery speed. With newer models, the difference in insulation is no longer an issue. New federal regulations in 2003 and 2004 mandated higher efficiencies in insulation and gas usage, as well as a new flammable vapor standard. (The standard now requires that if a flammable liquid is spilled the floor, that the vapors cannot be ignited outside of the combustion area of the water heater.) A temperature-pressure (T-P) relief valve must also be supplied with the tank.

When you bring the new heater home, be sure to transport it carefully, so you don't damage the carton and the tank inside. If you must move the heater up or down a staircase, use an appliance dolly. *NOTE: Inspect your new tank carefully – if the outer shell is dented, return the unit to the seller. The glass lining may be damaged on the inner tank, sharply reducing the lifespan of the unit.*

Start by shutting off the gas at the gas meter and the water to the heater. Open the bottom drain valve on the heater. A garden hose can be used to direct the water to the nearest drain and keep your work area somewhat drier. To speed up the water flow, open some of the faucets and lift the lever on the T-P relief valve to let air into the tank.

While the tank drains, begin to disconnect the pipes from the unit. If the water lines are soldered directly to fittings mounted in the tank, you'll need to cut the pipes as close to the fittings as possible. If the lines are connected to the tank with unions, it's a quick job of disassembly. With gas lines, it's a good idea to use two wrenches, so that you loosen only the parts that you need to take off. (If you do twist something loose, you will need to take it off and apply pipe joint compound – often called "pipe dope" – so there will be no new leaks.) When the water has drained out, slide the tank out of the way. Then move the new tank into position.

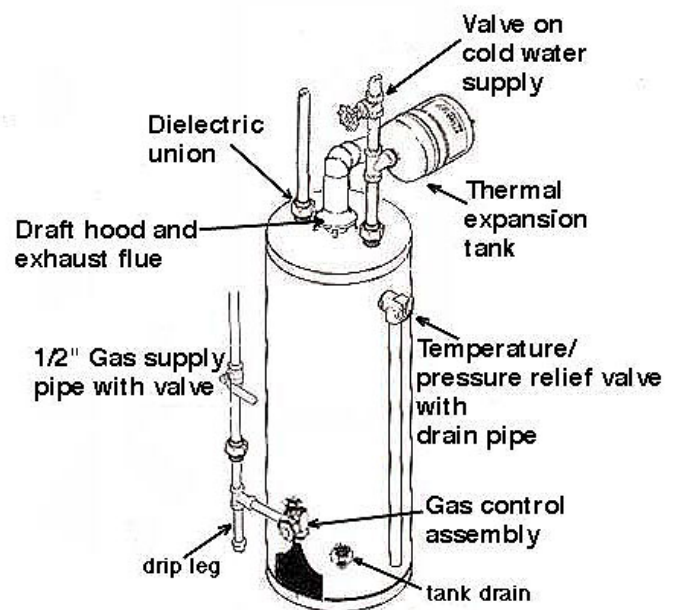

(continued)

For all gas and water lines, Ohio Plumbing Code requires that you use rigid pipe (not flexible connective lines.) If you have an old water-type (globe) valve on the gas supply line, remove it and replace it with a ball-type gas valve. Some city inspection departments insist on a new gas valve every time the water heater is replaced – which is not a bad idea. Be generous with the pipe joint compound on the male pipe threads, as this will keep the joints from leaking. After you have re-assembled the gas line, turn on the gas and test all the joints with soapy water for leaks.

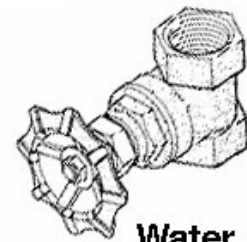

Water valve

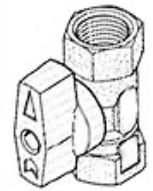

Gas valve

To attach the water lines, first install **dielectric unions** on the heater. (These unions isolate the steel tank from the copper in the water lines, to prevent the dissimilar metal from creating a weak electrical current that accelerates corrosion of the steel.) You can use either the pipe joint compound or Teflon thread tape to make the connection to the tank. Set the rubber washer aside and slip the nut and plastic collar onto the tubing. Hold the plastic collar out of the way before soldering the brass fitting to keep it from melting.



Dielectric Union

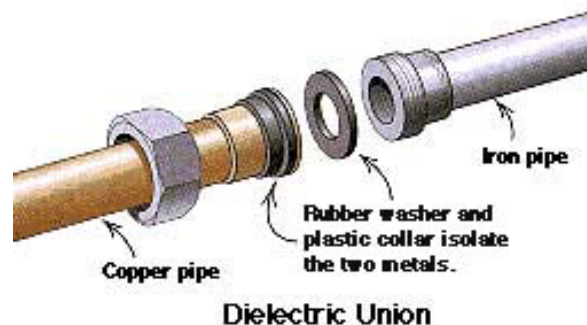

Dielectric Union

Polish the copper tube and the fitting with emery cloth, steel wool, or a wire brush. Apply flux (or a tinning flux) to both the tube and fitting before assembling. Heat the fitting with your propane torch, and then touch the solder to the joint. As the solder begins to melt and flow into the fitting, back the torch away. If there's too much heat, the solder will flow into the fitting beyond where you want it.

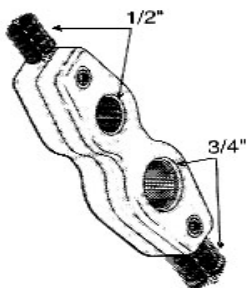

4-in-1 Wire Brush

If you have water dripping in the existing tubing, the joint will not get hot enough for the solder to melt. An old plumber's trick is to stuff some bread into the pipe; the bread will temporarily dam up the dripping and let you heat the joint long enough for the solder to flow.

Install a 3/4" copper drainpipe on the T-P relief valve to within 6 inches of the floor (*see tank illustration*). If there is a water pressure regulator (usually found next to the water meter) on your system, you'll also be required by Ohio Plumbing Code to install a thermal expansion tank on the cold water supply just above the tank. When all of your soldering is done, it's time to assemble the draft hood and flue pipe.

Inspect the draft hood that came with the new water heater to see what size flue pipe is required. If the existing flue pipe is the correct size, check it for corroded areas. Replace it with galvanized steel pipe if there are any holes or thin spots.

The flue pipe must rise towards the chimney from the tank at least 1/4" per foot, and all the crimped ends should point towards the chimney as you assemble it. Use self-drilling sheet metal screws (no more than 1/2" long) to attach the draft hood to the tank, and put two screws in each joint of the flue. Use mortar to seal the joint where the flue enters the chimney (*see illustration on next page.*)

(continued)

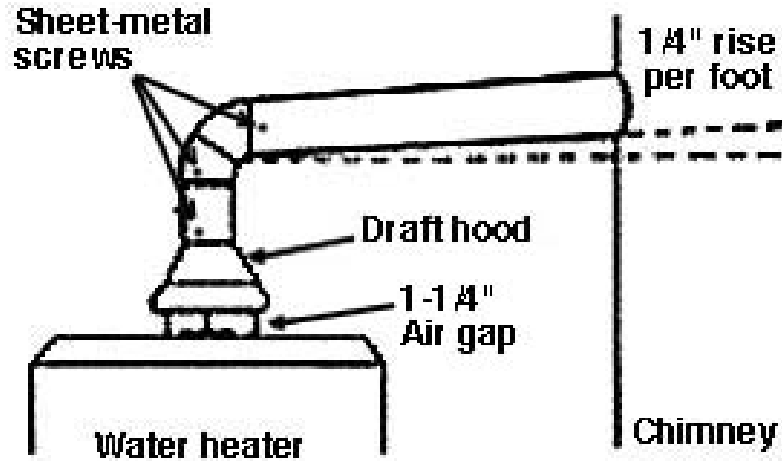

Check to make sure the flue is drafting properly by lighting a small piece of paper and immediately extinguishing the flame, leaving a trail of smoke. Place the smoldering paper near the gap between the top of the water heater and the bottom of the draft hood. The smoke should be drawn upwards into the flue.

Read your owner's manual for the sequence of lighting the pilot flame or "light". Remove the outer panel that covers the burner area and set the control knob on top of the gas control assembly to the "pilot" position. Hold down the pilot button for several moments to purge the air from the gas line; then, press the igniter button to light the pilot. Continue to hold down the pilot button for another minute or so while the thermocouple gets hot. Once the pilot remains lit, replace the cover panel and set the temperature knob to "hot" for the burner to light.

It will take about 45-to-60 minutes for the water to become hot. You may hear dripping in the burner area during that initial heat-up. Don't panic! It's just condensation from the flue inside the cold tank – there shouldn't be any dripping once the water is hot. If, after that first hour, you still hear dripping, check for leaks in the piping before tearing out the tank and replacing it with a new one.

Water heaters are usually warranted for five or ten years, but most last longer than the warranty period. The only routine maintenance necessary is to drain about a gallon of water from the bottom of the tank (or until it runs clear) twice a year. This draining will remove accumulated mineral deposits that could damage the glass lining and help the burner operate more efficiently. Also, periodically check the two valves on the tank; if one develops a leak, it can be easily replaced. Once the tank itself starts to leak, however, it's time to buy a new one.